

<b>Opening</b>	<b>60 in.</b>
<b>Rotation</b>	<b>Continuous</b>
<b>Rotator lifting capacity</b>	<b>9750 Lbs.</b>
<b>Torque at relief pressure</b>	<b>896 Ft-lbs. @ 2000 psi</b>
<b>Arm Construction</b>	<b>Hi-tensil T-1</b>
<b>Weight</b>	<b>1050 Lbs.</b>

Reference	Dimension
<b>A</b>	<b>60 in.</b>
<b>B</b>	<b>23 in.</b>
<b>C</b>	<b>32 in.</b>
<b>D</b>	<b>46 in.</b>
<b>E</b>	<b>56 in.</b>

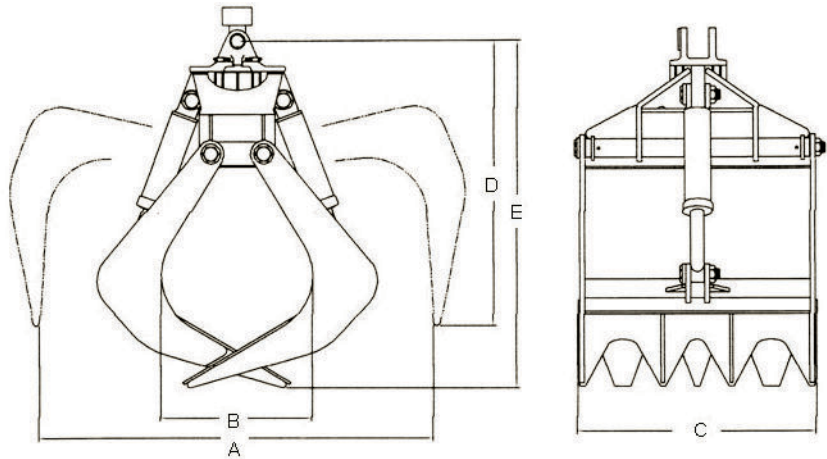

- FEATURES:**
1. Continuous rotation with vane rotator
  2. 1-1/2" diameter cylinder and 1-1/2" arm pivot pins
  3. Hard facing on arm tips

- OPTIONS:**
1. Various arm widths available
  2. High pressure cylinders

<b>Rotator: Indexator GV12</b>		<b>Maximum pressure: 3625 psi</b>		<b>Recommended flow: 6.6 gpm</b>	
Cylinder	Cylinder Bore	Recommended pressure	Pressure range	Flow @ 3 sec. closing time	
<b>Low Pressure</b>	<b>3-1/2"</b>	<b>2000 psi</b>	<b>1750 to 3000 psi</b>	<b>17 gpm</b>	
<b>High Pressure</b>	<b>3-1/2"</b>	<b>3000 psi</b>	<b>2500 to 5000 psi</b>	<b>25 gpm</b>	

NORTHSHORE MANUFACTURING RESERVES THE RIGHT TO CHANGE SPECIFICATIONS AND PRICES WITHOUT NOTICE IN ORDER TO FOLLOW ITS POLICY OF CONSTANTLY STRIVING TO MANUFACTURE A BETTER PRODUCT WITHOUT INCURRING ANY LIABILITY TO PROVIDE THESE NEW FEATURES ON ANY UNITS PREVIOUSLY MANUFACTURED.