



**BUILTRITE™**  
HANDLERS & ATTACHMENTS

# 2300-SE

**Stationary Electric Material Handlers  
Wristing Boom Option**



**Builrite™, Stationary Electric Material Handlers** have proven themselves in a number of waste and scrap handling applications, capable of handling a wide variety of materials. With a wide array of options, boom configurations and attachments available, let Builrite design a material handler to maximize production at your facility. Stationary Electric Material Handlers are much less expensive to operate, safer, quieter and don't produce emissions like diesel powered, mobile equipment. Maintenance costs are also less and the power unit can be remotely located where it is not subjected to dusty conditions, further reducing maintenance costs.

# 2300 SPECIFICATIONS - (WRISTING BOOM OPTION)

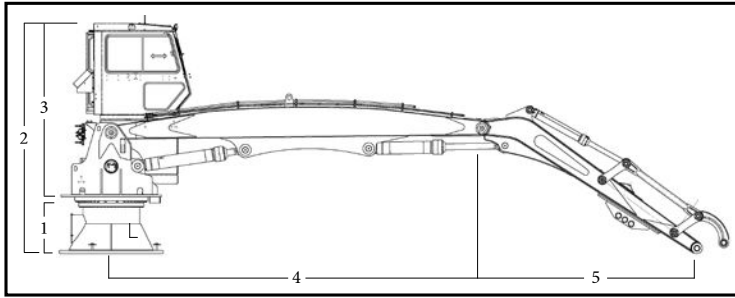

## DIMENSIONS

1	35.0" (89 CM)	5	13' (3.9 M)
2	13.0' (3.9 M) with standard 2' cab riser		
3	11' (3.3 M)		
4	20.0' (6.0 M)		

## BOOM DATA

- Horizontal Reach = 30'-33' (9.1 - 10M) straight, wristing styled boom (Other custom boom lengths available).
- Fabricated design, high yield steel construction.
- 4" (101 mm) boom pivot, 4.0" jib cylinder pin & 4.0" main boom lift cylinder pins (self aligning).
- Aluminum bronze bushings at all boom pivot points.

## HYDRAULICS

- 180 Gallon (697L) hydraulic reservoir with suction and return filters, stack type control valves with main relief and safety port relief for boom function.
- Pressure compensating, on demand hydraulic system.
- 4500 PSI (310 Bar) Operating System
- Hydraulic oil cooler. 3HP motor drives fan and AC compressor.

## BOOM CYLINDERS

- Main boom - One (1) 6.5" (165mm) bore x 4" (101mm) rod.
- Jib Boom - One (1) 6.5" (165mm) bore, x 4" (101mm) rod.
- Hydraulic stop cushions on both ends.
- Rods with heavy chrome plating.
- Accumulator on main lift cylinder to cushion shock loading.

## CONTROLS

- Two (2) electronic joystick controls with Parker, MD4 control console & G11 module (allows for remote diagnostics).
- Hand swing control.
- Controls can be set to customer preference.

## OPERATOR'S CAB

- 39" (990mm) x 62" (1,575mm), fully insulated, equipped with a sliding door & sliding window.
- Front window wiper & washer, defroster fan & dome light.
- Deluxe bucket seat.
- Cab heater, air conditioner and filtering pressurizer.
- Two (2) LED cab mounted work lights.
- Radio, CD & MP3 player.

## BOOM SWEEP

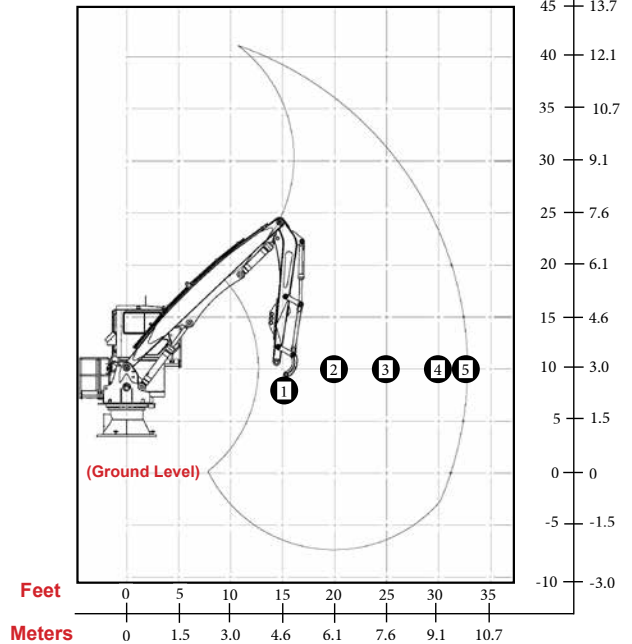

## LIFT CAPACITY **33' (9.1 m) Boom Option, Less Attachment** (Measured at 10' above ground level)

RADIUS	LIFT	RADIUS	LIFT
15' (3.0 M)	16600 lbs. (7530 KG)	30' (9.14 M)	7400 lbs. (3357 KG)
20' (6.1 M)	12000 lbs. (5443 KG)	33' (83.9 M)	6400 lbs. (2903 KG)
25' (7.6 M)	9200 lbs. (4173 KG)		

## SWING SYSTEM

- Up to 7.0 RPM with single motor and gearbox swing drive.
- 48" Diameter internal tooth bearing.

## MODULAR POWER SOURCE

- One (1) 150 HP 460 Volt 3 phase, totally enclosed, fan cooled (T.E.F.C.) electric motor.
- One (1) 3 HP 440 volt motor for air conditioning compressor drive.
- Self contained or remote mounted power unit.

## ELECTRICAL PACKAGE

- Starter, phase sequence monitor, control accessories group are all in Nema 4 enclosure.
- Start/stop controls on control console.
- Electric slip ring when continuous rotation is required.

## PEDESTAL BASE

- 33" (838mm) high pedestal base with inspection port hole.
- 68" (1,727mm), OD, round base plate.

## MISC.

- Centralized grease zerk location (standard).
- Optional auto-lube grease system.
- Optional continuous rotation option with auxiliary pass electrical collector.
- Optional rectifier package for magnet.



530 Recycle Center Drive • Two Harbors, MN 55616 • [builtrite.com](http://builtrite.com) • Phone: (218) 834-5555

We are TENAMEC—where tenacious and mechanical fuse. TENAMEC is proud to create the world's most durable material handling solutions under the Builtrite, SAS Forks and Lemco brands.

