

The **Builtrite™ Waste Clamshell Grapple** is designed with the professional waste processor in mind to provide maximum durability and low maintenance, reducing your downtime. This grapple is specifically designed to handle municipal solid waste and recyclables. Key features include:

- 360° continuous rotation, using a heavy duty bearing. Our rotators are designed for the specific carrier they are mounted to, providing long life with minimal maintenance requirements.
- Wide jaw opening and grapple width for handling large volumes of municipal solid waste (MSW) and recyclables.
- Cylinder shrouds protect the cylinders from external damage. Mechanical stops to prevent cylinders from bottoming out.
- Timing teeth bring both jaws simultaneously together.
- Bolt-on, wear resistant wear bars

If you're looking for the toughest, most durable grapple on the market, look no further...make it a **Builtrite™**.

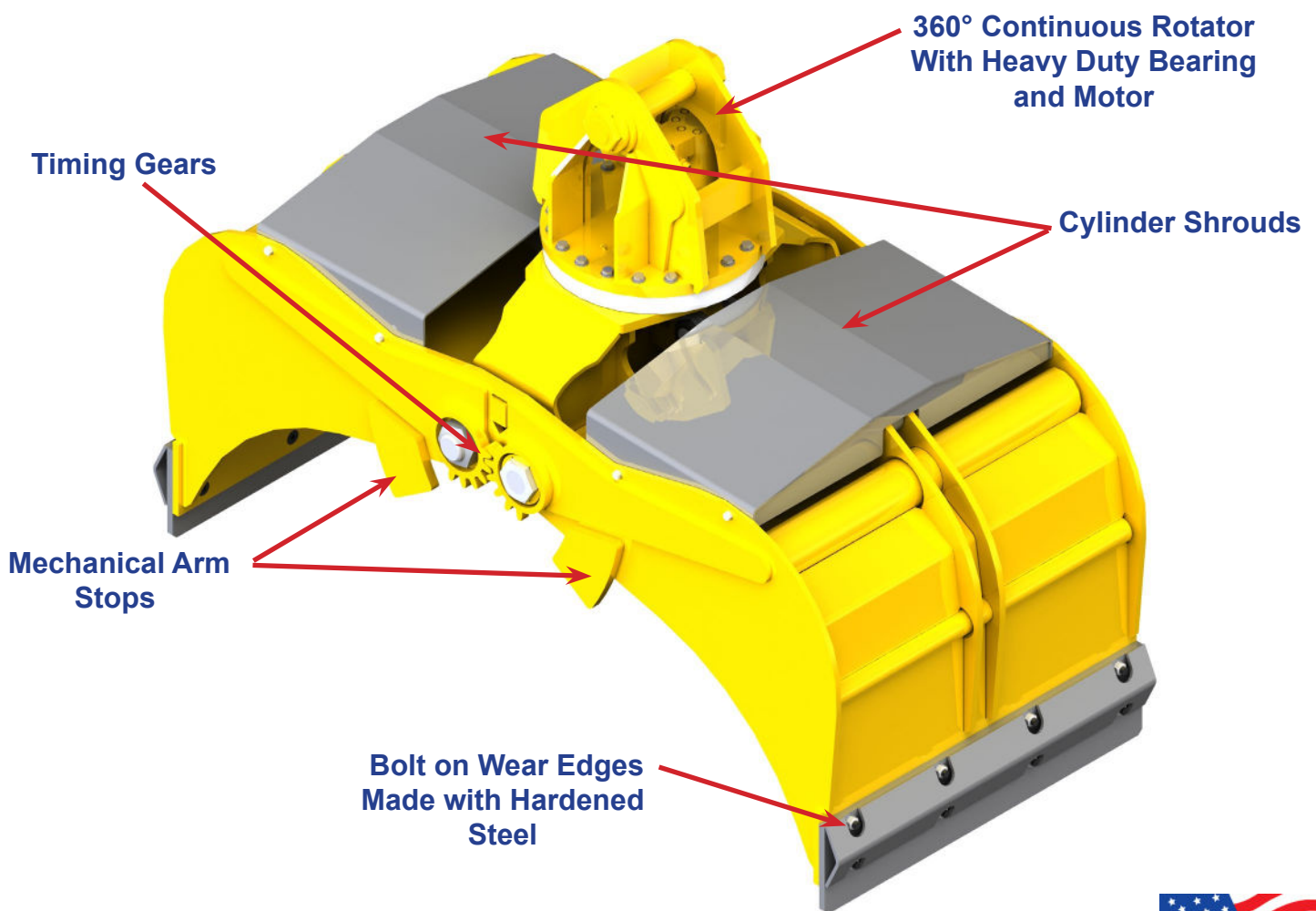

Waste Clamshell Grapple Specifications

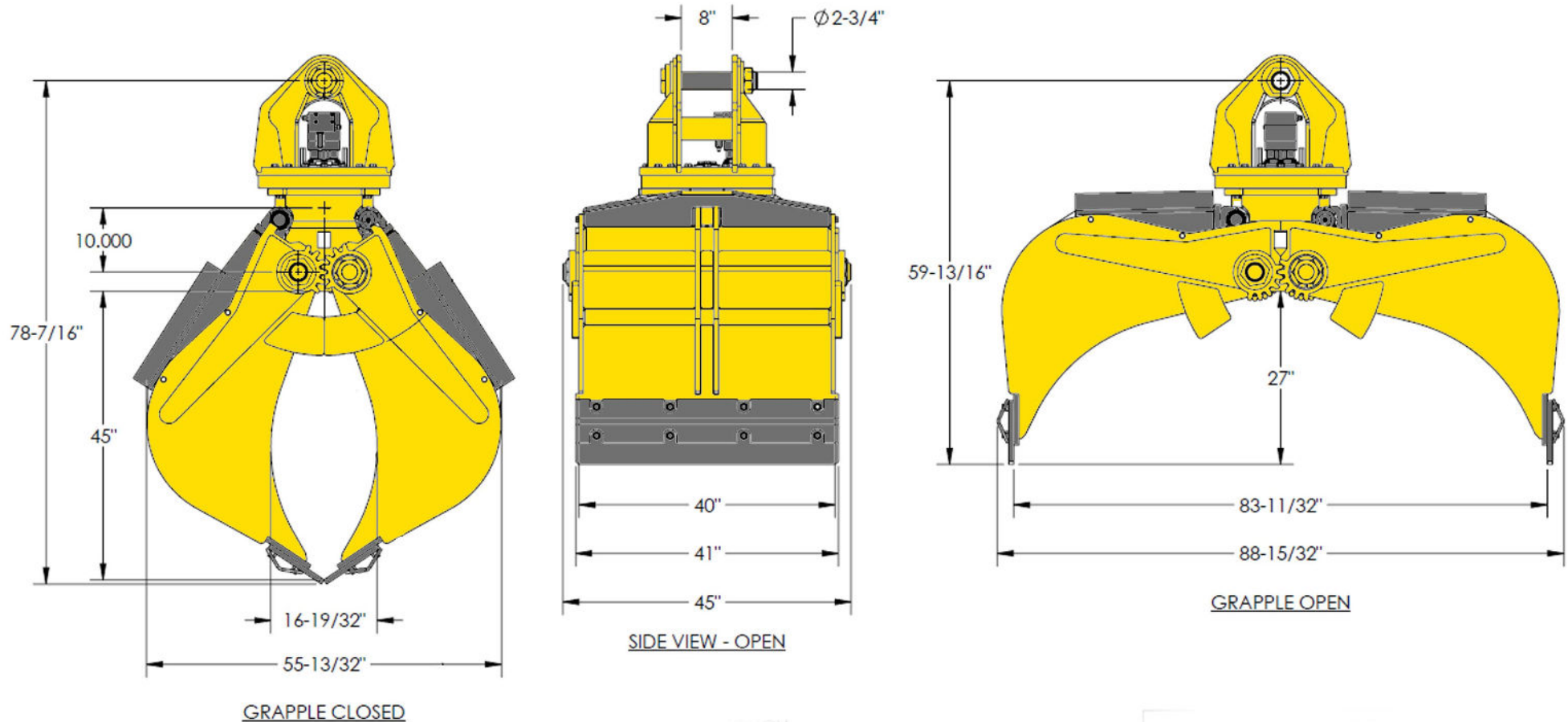

Weight = 3,530 Lbs./1,604 Kg.

HYDRAULIC REQUIREMENTS		
	Max. Flow GPM / LPM	Max. Pressure PSI / Bar
Waste Clamshell Grapple		
Open / Close	25 / 97	4500 / 310
Rotation	6 / 23	1750 / 121



BUILTRITE MANUFACTURING RESERVES THE RIGHT TO CHANGE SPECIFICATIONS AND PRICES WITHOUT NOTICE IN ORDER TO FOLLOW ITS POLICY OF CONSTANTLY STRIVING TO MANUFACTURE A BETTER PRODUCT WITHOUT INCURRING ANY LIABILITY TO PROVIDE THESE NEW FEATURES ON ANY UNITS PREVIOUSLY MANUFACTURED.

Builtrite Manufacturing

530 Recycle Center Drive, Two Harbors, Minnesota, U.S.A. 55616

Web: www.builtritehandlers.com E-Mail: info@builtritehandlers.com Phone: 218-834-5555 Fax: 218-834-5556